



■ FEATURES

- Ultra-miniature size (18.8 *15.4 *15.1 mm)
- High Switching Capacity up to 12A
- UL File No. E147052
- CSA File No. LR76479-1
- TUV File No. R9754066



■ COIL RATING (at 20°C)

Nominal Voltage (VDC)	Coil Resistance ($\Omega \pm 10\%$)	Nominal Current (mA)	Pick-Up Voltage (VDC)	Drop-Out Voltage (VDC)	Nominal Power (mW) Consumption
3	25	120	2.25	0.3	360
5	70	72	3.75	0.5	
6	100	60	4.50	0.6	
9	220	40	6.75	0.9	
12	400	30	9.00	1.2	
24	1600	15	18.00	2.4	
48	6400	7.5	36.00	4.8	

■ ORDERING INFORMATION

- BS-115C S-A-12A-12VDC

Protection	Contact Arrangement	Contact Rating	Coil Voltage
Nil: Flux Free S : Sealed	Nil: 1 Form C A: 1 Form A	7A 12A	See Coil Rating

■ SPECIFICATIONS

Model No.	BS-115C-7A	BS-115C-12A
Contact Arrangement	1 Form A, 1 Form C	
Contact Material	AgCdO	
Contact Rating (at Resistive Load)	7A 120VAC 5A 240VAC/28VDC	12A 120VAC 10A 240VAC/28VDC
Max. Switching Voltage	240VAC, 60VDC	
Max. Switching Current	7A	12A
Min. Switching Load	100mA 5VDC	
Contact Resistance	Max. 100mΩ (initial)	
Insulation Resistance	Min. 100MΩ at 500VDC	
Dielectric Strength		
Between Contacts	750VAC 50 HZ/60 HZ (1 minute)	
Between Coil & Contact	1500VAC 50 HZ/60 HZ (1 minute)	
Surge Strength	2000V	
Operate Time	Max. 10mSec.	
Release Time	Max. 5mSec.	
Ambient Temperature	-30°C ~ +55°C	
Vibration Resistance (Endurance)	1.5mm D.A. 10-55HZ	
Shock Resistance	Min. 10G Unerror	
Mechanical Life	5,000,000 Operations (no load)	
Electrical Life	100,000 Operations (at rated load)	
Weight	Approx. 8g	

DIMENSIONS (in mm)

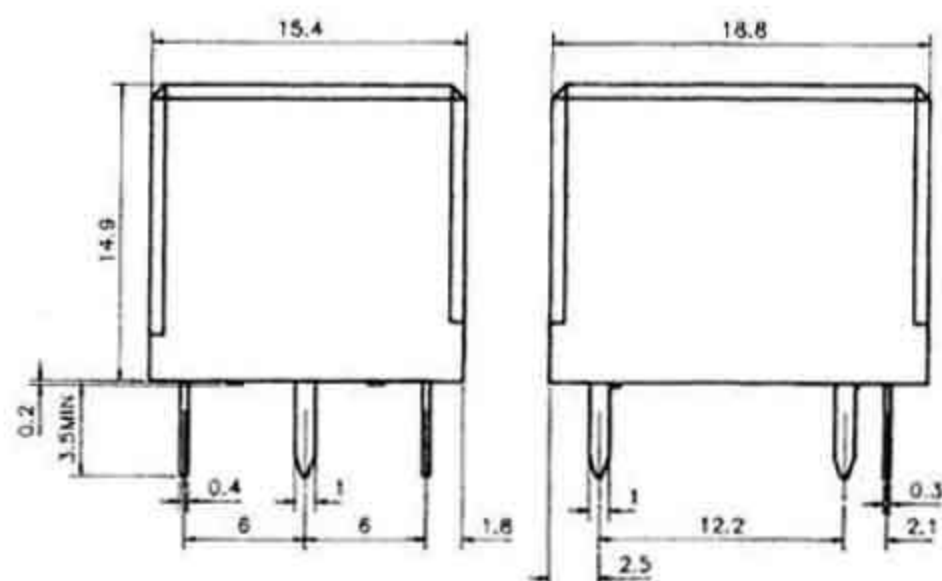

WIRING DIAGRAM (Bottom View)

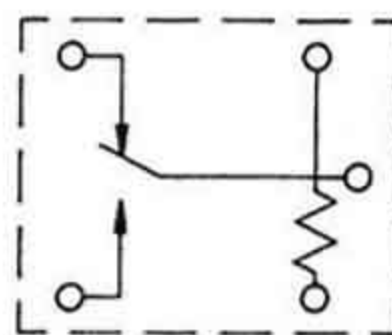

DRILLING PLAN (in mm)

